

Low Resistance Flat Chip Resistors

Type SR73

ISO 9001:2008 CERTIFIED
TS-16949 CERTIFIED



1. Scope

This specification applies to chip resistors (SR73) produced by KOA Corporation.

2. Type Designation

The type designation shall be in the following form:

SR73	2B	T	TD	1R00	F
Size	Size	Termination Material	Packaging	Nominal Resistance	Tolerance
1H 1E 1J 2A 2B 2E W2H W3A 2H 3A	1H 1E 1J 2A 2B 2E W2H W3A 2H 3A	T: Sn L: SnPb (1E, 1J, 2A, 2B, 2E, 2H, 3A) G: Au (1J, 2A, 2B: 0.1Ω - 10Ω - contact factory)	TC: 0201 only: 7" 2mm pitch pressed paper (TC: 10,000 pcs/reel, TCM: 15,000 pcs/reel) TPL: 0402 only: 2mm pitch punch paper TP: 0402, 0603, 0805: 7" 2mm pitch punch paper TD: 0603, 0805, 1206, 1210: 7" 4mm pitch punched paper TDD: 0603, 0805, 1206, 1210: 10" paper tape TE: 0805, 1206, 1210, 2010 & 2512: 7" embossed plastic TED: 0805, 1206, 1210, 2010 & 2512: 10" embossed plastic	±2%, ±5%: 2 significant figures + 1 multiplier "R" indicates decimal on value <10Ω ±1%: 3 significant figures + 1 multiplier "R" indicates decimal on value <100Ω All values less than 0.1Ω (100mΩ) are expressed in mΩ with "L" as decimal Example: 20mΩ = 20L (3-digit)	D: ±0.5% F: ±1% G: ±2% J: ±5%

3. Dimensions and Structure

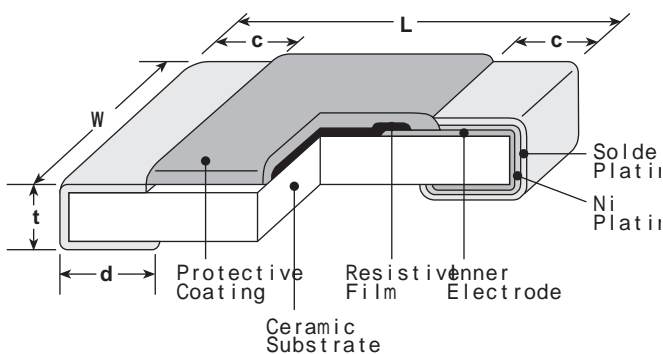

Type (Inch Size Code)	Dimensions inches (mm)				
	L	W	c	d	t
1H (0201)	.024±.001 (0.6±0.03)	.012±.001 (0.3±0.03)	.004±.002 (0.1±0.05)	.006±.002 (0.15±0.05)	.009±.001 (0.23±0.03)
1E (0402)	.039 ^{+0.004} _{-.002} (1.0 ^{+0.1} _{-0.05})	.02 ^{+0.004} _{-.002} (0.5 ^{+0.1} _{-0.05})	.01±.004 (0.25±0.1)	.01±.004 (0.25±0.1)	.014±.002 (0.35±0.05)
1J (0603)	.063±.008 (1.6±0.2)	.031 ^{+0.006} _{-.004} (0.8 ^{+0.15} _{-0.1})	.014±.004 (0.35±0.1)	.014±.004 (0.35±0.1)	.018±.004 (0.45±0.1)
2A (0805)	.079±.008 (2.0±0.2)	.049±.004 (1.25±0.1)	.016±.008 (0.4±0.2)	.012 ^{+0.008} _{-.004} (0.3 ^{+0.2} _{-0.1})	.02±.004 (0.5±0.1)
2B (1206)	.126±.008 (3.2±0.2)	.063±.008 (1.6±0.2)	.02±.012 (0.5±0.3)	.016 ^{+0.008} _{-.004} (0.4 ^{+0.2} _{-0.1})	.024±.004 (0.6±0.1)
2E (1210)	.102±.008 (2.6±0.2)				
2H (2010)	.197±.008 (5.0±0.2)	.098±.008 (2.5±0.2)			
W2H (2010)				.026±.006 (0.65±0.15)	
3A (2512)	.248±.008 (6.3±0.2)	.122±.008 (3.1±0.2)		.016 ^{+0.008} _{-.004} (0.4 ^{+0.2} _{-0.1})	
W3A (2512)				.026±.006 (0.65±0.15)	

4. Standard Applications

Part Designation*	Power Rating @ 70°C	Rated Ambient Temp.	Rated Terminal Part Temp.	T.C.R. (ppm/°C) Max.	Resistance Range				Absolute Maximum Working Voltage	Maximum Overload Voltage (5 Secs. Max.)
					E-24, E-96 (D±0.5%)	E-24, E-96 (F±1%)	E-24 (G±2%)	E-24 (J±5%)		
SR731H (0201)	0.1W	70°C	—	0 - ±400	—	1Ω - 10Ω**	—	0.27Ω - 10Ω	1.0V	2.5V
				0 - ±500		—		0.18Ω - 0.24Ω		
SR731E (0402)	1/6W (.166W)	70°C	125°C	±200	—	0.51Ω - 10Ω**	0.51Ω - 10Ω	0.51Ω - 10Ω	1.11V	2.79V
				±300	—	0.2Ω - 0.47Ω**	0.2Ω - 0.47Ω	0.2Ω - 0.47Ω		
				±500	—	0.1Ω - 0.18Ω**	0.1Ω - 0.18Ω	0.1Ω - 0.18Ω		
SR731J (0603)	1/5W (.2W)	70°C	125°C	±200	—	0.1Ω - 10Ω	0.1Ω - 10Ω	0.1Ω - 10Ω	1.41V	3.53V
SR732A (0805)	1/3W (.33W)	70°C	125°C	±100	0.15Ω - 10Ω	0.1Ω - 10Ω	—	—	1.58V	3.95V
				±200	—	—	0.1Ω - 10Ω	0.1Ω - 10Ω		
				±500	—	—	—	0.051Ω - 0.091Ω		
	1/2W (.5W')	—	105°C	±800	—	—	—	0.030Ω - 0.047Ω	—	—
				±100	0.15Ω - 10Ω	0.1Ω - 10Ω	—	—		
				±200	—	—	0.1Ω - 10Ω	0.1Ω - 10Ω		
SR732B (1206)	1/3W (.33W)	70°C	125°C	±500	—	—	—	0.056Ω - 0.091Ω	1.81V	4.54V
				±800	—	—	—	0.030Ω - 0.051Ω		
				±100	0.15Ω - 10Ω	0.1Ω - 10Ω	—	—		
	1/2W (.5W')	—	110°C	±200	—	—	0.1Ω - 10Ω	0.1Ω - 10Ω	—	—
				±500	—	—	—	0.056Ω - 0.091Ω		
				±800	—	—	—	0.030Ω - 0.051Ω		
SR732E (1210)	1/2W (.5W)	70°C	125°C	±100	—	0.1Ω - 10Ω	—	—	2.23V	5.59V
				±200	—	—	0.1Ω - 10Ω	0.047Ω - 10Ω		
				±500	—	—	—	0.036Ω - 0.043Ω		
	2/3W (.66W')	—	110°C	±800	—	—	—	0.024Ω - 0.033Ω	—	—
				±100	0.15Ω - 10Ω	0.1Ω - 10Ω	—	—		
				±200	—	—	0.1Ω - 10Ω	0.047Ω - 10Ω		
SR732H/W2H (2010)	3/4W (.75W)	70°C	125°C	±500	—	—	—	0.056Ω - 0.091Ω	2.73V	6.84V
				±800	—	—	—	0.033Ω - 0.051Ω		
				±100	—	0.1Ω - 10Ω	—	—		
	1W	70°C	125°C	±200	—	—	0.1Ω - 10Ω	0.1Ω - 10Ω	3.16V	7.90V
				±500	—	—	—	0.056Ω - 0.091Ω		
				±800	—	—	—	0.039Ω - 0.051Ω		

* Parentheses indicate EIA package size codes. ** 1H, 1E (F: ±1%) E-24 values only. Operating Temp: -55C to +125°C (SR731H only), -55°C to +150°C
 If any questions should arise whether to use the "Rated Ambient Temperature" or the "Rated Terminal Part Temperature," please give priority to the "Rated Terminal Part Temperature." Prior to use and for more details refer to "Introduction of the derating curves on the terminal part temperature" in the beginning of the catalog.
 † Prior to use, refer to the "Higher Power Ratings" in the beginning of catalog.

5. Rating

Derating Curve

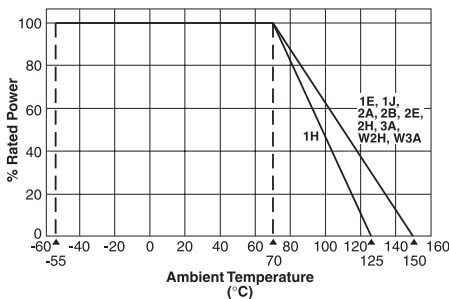

For resistors operated at an ambient temperature of 70°C or above, a power rating shall be derated in accordance with the derating curve.

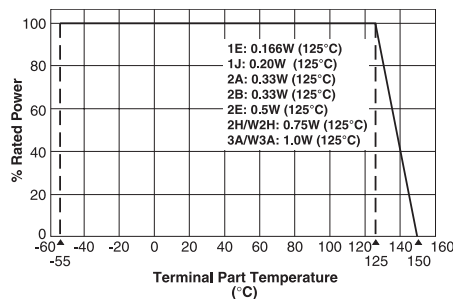

For resistors operated at a terminal part temperature of described for each size or above, a power rating shall be derated in accordance with the derating curve.

Please refer to "Introduction of the derating curve based on the terminal part temperature" on the beginning of our catalog before use.

SR73 2A (0.5W), SR73 2B (0.5W), SR73 2E (0.66W)

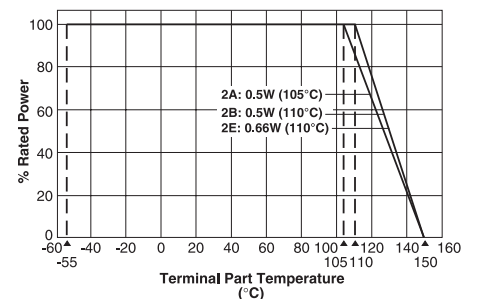

5-2 Voltage Rating

Resistors shall have a rated direct-current (DC) continuous working voltage or approximate sine-wave root-mean-square (RMS) continuous working voltage at commercial-line frequency and waveform corresponding to the power rating, as determined from the following formula:

$E = \sqrt{P \times R}$	Where: E = Rated voltage (V) P = Rated power (W) R = Nominal resistance (Ω)
-------------------------	---

In no case shall be rated DC or R.M.S. continuous working voltage be greater than the applicable maximum value.

6. Body and Marking

Type	Tolerance	Coating Color	Marking Color
SR73	D ($\pm 0.5\%$) F ($\pm 1\%$)	Indigo	White/ 4 digit
SR73	G ($\pm 2\%$) J ($\pm 5\%$)	Indigo	White/ 3 digit

Marking: a effective number and a multiplier. R means a decimal point.

7. Marking Method

D, F	4 digit	This character indicate Ω unit and express 4 effective numbers. R means a decimal point.
G, J	3 digit	This character indicate Ω unit and express 3 effective numbers. R means a decimal point.

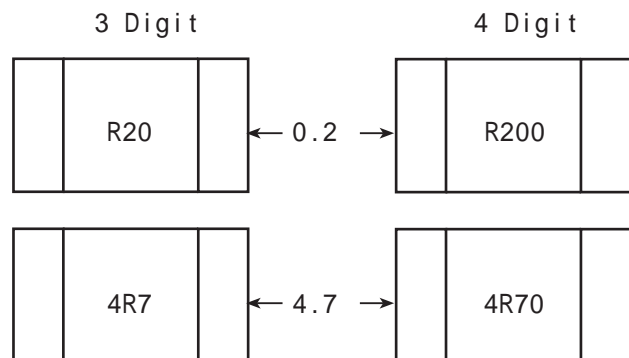

8. Performance Characteristics

Parameter	Requirement $\Delta R \pm(\%+0.05\Omega)$		Test Method
	Limit	Typical	
Resistance	Within specified tolerance	—	25°C
T.C.R.	Within specified T.C.R.	—	+25°C/-55°C and +25°C/+125°C
Overload (Short time)	±2%	±0.5%	Rated Voltage x 2.5 for 5 seconds
Resistance to Solder Heat	1H: ±3%, 1E~W3A: ±1%	1H: ±0.75% 1E~W3A: ±0.3%	260°C ± 5°C, 10 seconds ± 1 second
Rapid Change of Temperature	±1%	±0.3%	-40°C (30 minutes), +125°C (30 minutes), 100 cycles
Moisture Resistance	1H: ±3% 1E~W3A: ±2%	±1%	40°C ± 2°C, 90%-95% RH, 1000 hours, 1.5 hr ON, 0.5 hr OFF cycle
Endurance at 70°C	1H: ±3% 1E~W3A: ±2%	±1%	70°C ± 2°C, 1000 hours, 1.5 hr ON, 0.5 hr OFF cycle
High Temperature Exposure	±1%	±0.3%	1H: +125°C, 1000 hours; 1E, 1J, 2A, 2B, 2E, 2H/W2H, 3A/W3A: +150°C, 1000 hours

9. Recommended Land Dimensions

9-1 Reflow Soldering

Dimensions in inches (mm)

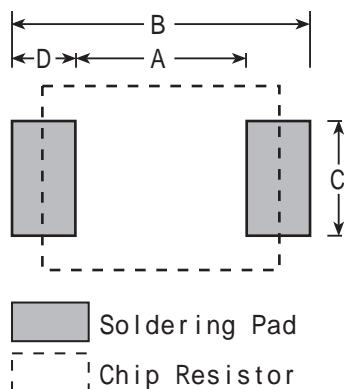

Type	Style	Resistor Size	A	B	C	D
SR73	1 F	0.016 x 0.008 (0.4 x 0.2)	0.005 (0.12)	0.019 (0.48)	0.007 (0.18)	0.007 (0.18)
	1 H	0.024 x 0.012 (0.6 x 0.3)	0.010 (0.25)	0.028 (0.7)	0.012 (0.3)	0.009 (0.225)
	1 E	0.039 x 0.020 (1.0 x 0.5)	0.020 (0.5)	0.051 (1.3)	0.012 (0.3)	0.016 (0.4)
	1 J	0.063 x 0.031 (1.6 x 0.8)	0.039 (1.0)	0.079 (2.0)	0.024 (0.6)	0.020 (0.5)
	2 A	0.079 x 0.049 (2.0 x 1.25)	0.051 (1.3)	0.098 (2.5)	0.041 (1.05)	0.024 (0.6)
	2 B	0.126 x 0.063 (3.2 x 1.6)	0.087 (2.2)	0.157 (4.0)	0.055 (1.4)	0.035 (0.9)
	2 E	0.126 x 0.098 (3.2 x 2.5)	0.087 (2.2)	0.157 (4.0)	0.091 (2.3)	0.035 (0.9)
	2 H	0.197 x 0.098 (5.0 x 2.5)	0.138 (3.5)	0.248 (6.3)	0.091 (2.3)	0.055 (1.4)
	3 A	0.252 x 0.126 (6.4 x 3.2)	0.181 (4.6)	0.315 (8.0)	0.118 (3.0)	0.067 (1.7)

10. Taping

10-1 Taped Configuration

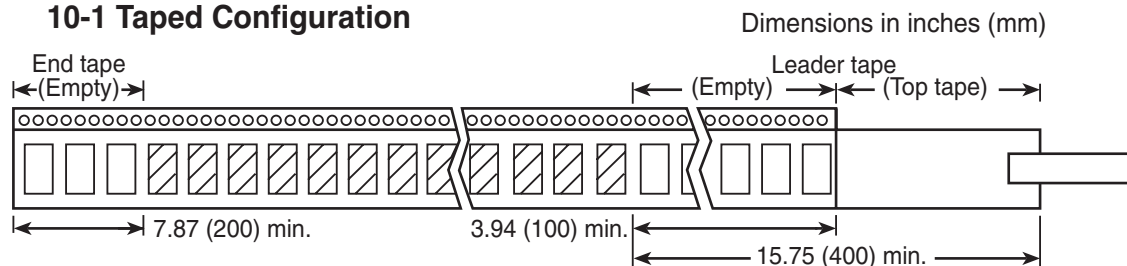

10-2 Dimensions of Punched Paper Tape

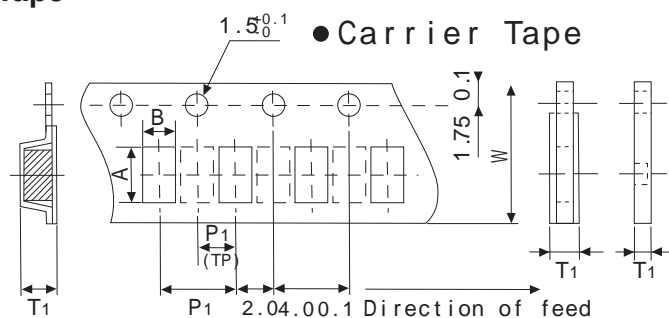

(Notes) Dotted lines are applicable to only "TP" and "TB."

Type	Component Size (mm)			Carrier Tape	Quantity/ Reel (Pieces)	Taping (mm)					Reel Size	
	L	W	T			A	B	W	P1	T1		
SR73	1F	0.4	0.2	0.12	TX	40000	0.25±0.04	0.45±0.04	4.0±0.2	1.0±0.05	0.40±0.1	180
					TBL	20000	0.25±0.03	0.45±0.03	8.0±0.2	2±0.05	0.31+0.2/-0	178
	1H	0.6	0.3	0.23	TA	35000	0.67±0.05	0.37±0.05	8.0±0.2	1±0.05	0.42±0.1	178
					TC/TCM	10000/15000	0.67±0.05	0.37±0.05	8.0±0.2	2±0.05	0.42±0.1	178
	1E	1	0.5	0.35	TPL*	20000	1.15±0.1	0.65±0.1	8.0±0.2	2±0.05	0.42+0.2/-0	178
					TP	10000	1.15±0.1	0.65±0.1	8.0±0.2	2±0.05	0.42+0.2/-0	178
	1J	1.6	0.8	0.45	TP	10000	1.9±0.1	1.1±0.1	8.0±0.2	2±0.05	0.6+0.2/-0	178
					TD	5000	1.9±0.1	1.1±0.08	8.0±0.2	4.0±0.1	0.6+0.2/-0	178
					TDD	10000	1.9±0.1	1.1±0.1	8.0±0.2	4.0±0.1	0.6+0.2/-0	255
					TP	10000	2.4±0.2	1.65±0.2	8.0±0.2	2±0.05	0.75+0.2/-0	178
	2A	2	1.25	0.5	TD	5000	2.4±0.2	1.65±0.2	8.0±0.2	4.0±0.1	0.75+0.2/-0	178
					TE	4000	2.4±0.2	1.6±0.2	8.0±0.2	4.0±0.1	0.9±0.1	178
					TDD	10000	2.4±0.1	1.65±0.1	8.0±0.2	4.0±0.1	0.75+0.2/-0	255
					TED	10000	2.4±0.2	1.45±0.15	8.0±0.2	4.0±0.1	0.65±0.1	255
					TD	5000	3.5±0.2	2±0.2	8.0±0.2	4.0±0.1	0.75+0.2/-0	178
	2B	3.2	1.6	0.6	TE	4000	3.5±0.2	1.9±0.2	8.0±0.2	4.0±0.1	1.0±0.1	178
					TDD	10000	3.5±0.1	1.9±0.1	8.0±0.2	4.0±0.1	0.75+0.2/-0	255
					TED	10000	3.5±0.1	1.9±0.2	8.0±0.2	4.0±0.1	1.0±0.1	255
					TD	5000	3.5±0.2	2.85±0.2	8.0±0.2	4.0±0.1	0.75+0.2/-0	178
	2E	3.2	2.6	0.6	TE	4000	3.5±0.2	2.85±0.2	8.0±0.2	4.0±0.1	1.0±0.15	178
TDD					10000	3.5±0.1	2.8±0.1	8.0±0.2	4.0±0.1	0.75+0.2/-0	255	
TED					10000	3.6±0.15	2.9±0.15	8.0±0.2	4.0±0.1	1.0±0.1	255	
TE					4000	5.35±0.2	2.9±0.2	12.0±0.1	4.0±0.1	1.0±0.15	178	
2H/W2H	5	2.5	0.6	TED	10000	5.4±0.2	2.9±0.2	12.0±0.1	4.0±0.1	0.85±0.1	255	
				TE	4000	6.65±0.2	3.44±0.2	12.0±0.1	4.0±0.1	1.0±0.15	178	
3A/W3A	6.3	3.1	0.6	TED	10000	6.9±0.2	3.6±0.2	12.0±0.1	4.0±0.1	0.85±0.1	255	

11-5 Dimensions of Reel

Dimensions in inches (mm)

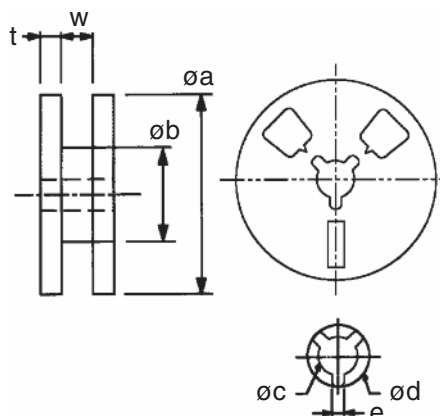

Size Code	øa max.		øb	w	t	øc	ød	e
	7"	10"						
1 H (0201)	7.008 (178)	10.039 (255)	3.150 (80 ± 2.0)	0.394 (10 ± 1.0)	.059 (1.5 ± 0.05)	0.512 (13 ± 0.5)	1.063 (27 ± 2.0)	.118 (3.0 ± 0.5)
1 E (0402)								
1 J (0603)								
2 A (0805)	7.008 (178)	10.039 (255)	2.362 (60 ± 2.0)	0.551 (14 ± 1.0)	.059 (1.5 ± 0.05)	0.512 (13 ± 0.5)	.827 (21 ± 2.0)	.079 (2.0 ± 0.5)
2 B (1206)								
2 E (1210)								
2 H (2010)								
3 A (2512)								

Quantity per reel or reel size are requested to designate at the time of ordering.

Contents on label:

- | | |
|---|--|
| (1) Article number (SR73K2ATD J) | (4) Customer's code number (subject to change) |
| (2) Quantity | (5) Production lot number |
| (3) Nominal Resistance and the chip marking [Ex: 0.2 Ω (R20)] | (6) Manufacturer's name |

10. Packing

Lot number (8 digits)

23

12

3001

Production
year, month

Date

Additional
day number

47~58	January 2011 ~ December 2014
59~70	January 2012 ~ December 2015

11. Packaging Method

Size Code	TCM 7" Pressed Paper	TPL Punched Paper	TE 7" Embossed Plastic	TP 7" Punched Paper	TD Punched Paper	TED 10" Embossed Plastic	TDD 10" Punched Paper
1H (0201)	15,000	—	—	—	—	—	—
1E (0402)	—	20,000	—	10,000	—	—	—
1J (0603)	—	—	—	10,000	5,000	—	10,000
2A (0805)	—	—	4,000	10,000	5,000	10,000	10,000
2B (1206)	—	—	4,000	—	5,000	10,000	10,000
2E (1210)	—	—	4,000	—	5,000	10,000	10,000
2H (2010)	—	—	4,000	—	—	10,000	—
W2H (2010)	—	—	4,000	—	—	10,000	—
3A (2512)	—	—	4,000	—	—	10,000	—
W3A (2512)	—	—	4,000	—	—	10,000	—