

Surface Mount Coat-insulated Fixed Metal Film Resistors

ISO 9001:2008
CERTIFIED
TS-16949
CERTIFIED

RN41, RM41 Type

1. Features

- High stability in short and long term tests
- Marking: Blue body color for “RN”, green for “RM”
- Products with lead-free terminations meet EU RoHS and China requirements
- AEC-Q200 Qualified: RN412ES, RN413AS only

2. Dimensions and Construction

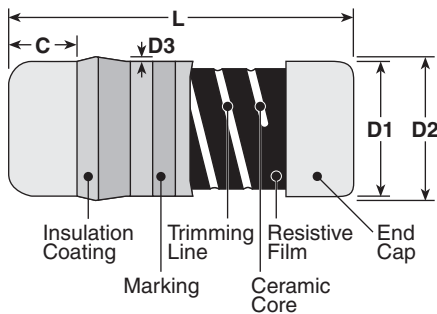

Type (Inch/DIN Size Code)	Dimensions inches (mm)				
	L	C	D1	D2 (max.)	D3 (max.)
2A (0805/0102)	.079±.004 (2.0±0.1)	.012 (0.3 min.)	.049±.002 (1.25±0.05)	.053 (1.35)	.003 (0.07)
2D (1206/0203)	.126±.008 (3.2±0.2)	.02 (0.5 min.)	.061±.006 (1.55±0.15)	.069 (1.75)	.004 (0.1)
2ES (1406/0204)	.138±.008 (3.5±0.2)	.02 ~ .035 (0.5 ~ 0.9)	.055±.004 (1.4±0.1)	.061 (1.55)	
2E, 2H, 3AS (2309/0207)	.232±.008 (5.9±0.2)	.02 (0.5 min.)	.087±.004 (2.2±0.1)	.094 (2.4)	.006 (0.15)

3. Type Designation

The type designation shall be the following form:

New Type

RN41	2B	T	TE	1002	J	50*
Dielectric	Size	Termination Material	Packaging	Nominal Resistance	Tolerance	T.C.R. (ppm/°C)
RN41	2A: 0805 2B: 1406 2D: 1206 2E: 2309 2ES: 1406 2H: 2309 3AS: 2309	T: Sn	TE: 7" Embossed Plastic (2A, 2ES - 3,000 pcs/reel) (2D - 2,000 pcs/reel) (2E, 2H, 3AS - 1,500 pcs/reel)	±5%: 2 significant figures + 1 multiplier. "R" indicates decimal on values <10Ω ±1%: 3 significant figures + 1 multiplier. "R" indicates decimal on values <100Ω	B = ±0.1% C = ±0.25% D = ±0.5% F = ±1% J = ±5%	25 50 100 200

*T.C.R. noted for RN41 only

PAGE 1 OF 4

3. Type Designation (continued)

The type designation shall be the following form:

New Type

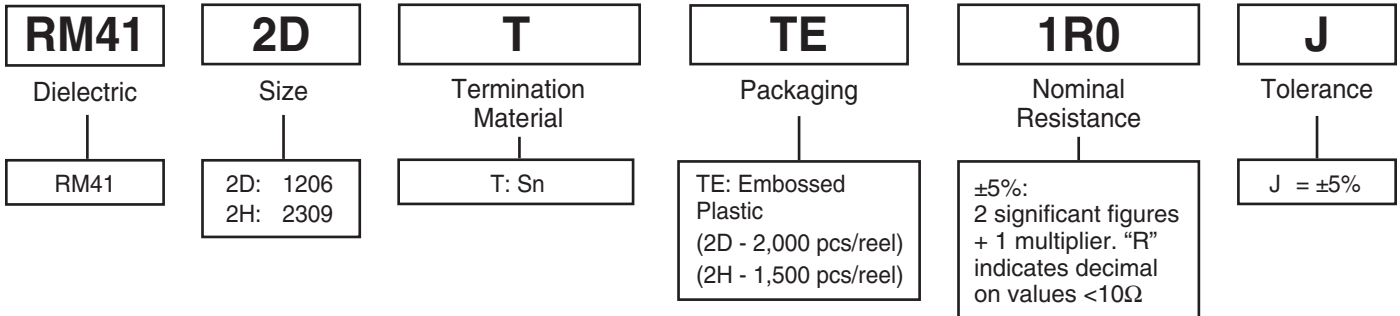

4. Applications and Ratings

Part Designation	Power Rating @ 70°C	T.C.R. (ppm/°C) Max.	Resistance Range					Absolute Maximum Working Voltage	Absolute Maximum Overload Voltage	Operating Temperature Range
			(B±0.1%)	E-24, E-96 (C±0.25%)	E-24, E-96 (D±0.5%)	E-24, E-96 (F±1%)	E-24 (J±5%)			
RN412A	1/8W (.125W)	±100	—	—	—	100Ω-100KΩ	—	150V	200V	-55°C to +155°C
RN412D	1/5W (.2W)	±50	—	—	—	10Ω-604KΩ	—		300V	
RN412E	1/4W (.25W)	±25	—	100Ω-100KΩ	100Ω-1MΩ	—	—	250V	500V	
		±50	—	—	—	10Ω-1.0MΩ	—			
RN412ES	1/4W (.25W)	±25	43Ω-511KΩ	100Ω-100KΩ	100Ω-604KΩ	—	—	200V	400V	
		±50	—	—	—	1Ω-5.11MΩ	0.22Ω-0.91Ω			
RN412H	1/2W (.5W)	±200	—	—	—	—	0.22Ω-100KΩ	250V	600V	
RM412D	1/5W (.2W)	±350	—	—	—	—	0.22Ω-8.2Ω (E-12)	$\sqrt{P \times R}$	$\sqrt{P \times R \times 6.25}$	
RM412H	1/2W (.5W)	±350	—	—	—	—	—	—	—	
RN413AS	1W*	±50	—	—	—	1Ω-1MΩ	0.22Ω-0.91Ω	400V	600V	

* A power rating shall be guaranteed with a method shown in the Performance Characteristics. Please contact factory prior to use.

5. Environmental Application

Derating Curve

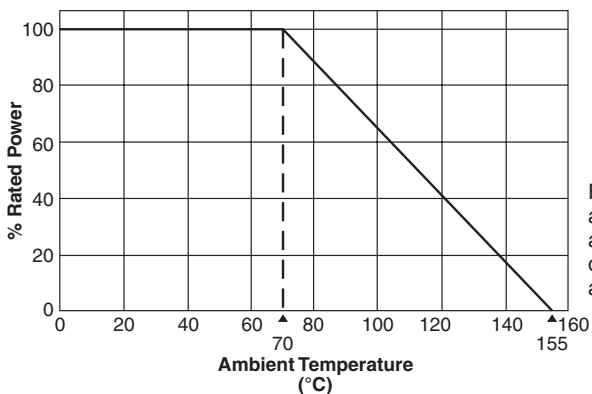

For resistors operated at an ambient temperature of 70°C or above, a power rating shall be derated in accordance with the above derating curve.

Surface Temperature Rise

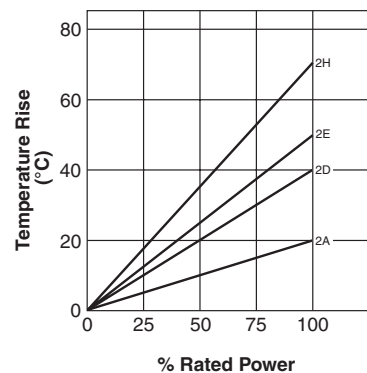

6. Performance Characteristics

Parameter	Requirement $\Delta R \pm(\%+0.05\Omega)$		Test Method
	Limit	Typical	
Resistance	Within specified tolerance	—	25°C
T.C.R.	Within specified T.C.R.	—	+25°C/-55°C, +25°C/+125°C
Overload (Short time)	±0.5%	±0.3%	Rated voltage x 2.5 for 5 seconds
Intermittent Overload	±1%: RN41 2A,2D,2H ±0.5%: RM41 2E	—	Rated voltage x 4 (2Ax3) or Max. intermittent overload voltage, whichever is lower, 10,000 cycles. 2A: 200V, 2D: 300V, 2E: 500V, RN2H: 600V
Resistance to Soldering Heat	±2%: 2H (10Ω>) ±1%: 2H (10Ω≤) ±0.5%: RN 2A~2E	±1%: 2H (10Ω>) ±0.5%: 2H (10Ω≤) ±0.3%: RN 2A~2E	260°C ± 5°C, 10 seconds ± 1 second
Rapid Change of Temperature	±0.5%: RN41 2A~2E ±1%: RN41 2H ±1%: RM41	±0.3%: RN41 2A~2E ±0.7%: RN41 2H ±0.75%: RM41	-55°C (30 minutes), +125°C (30 minutes), 5 cycles
Moisture Resistance	±1%: RN41 2D,2E ±3%: RN41 2A ±5%: RN41 2H ±5%: RM41	±0.75%: RN41 2D,2E ±1.5%: RN41 2A ±3%: RN41 2H ±3%: RM41	40°C ± 2°C, 90 ~ 95% RH, 1000 hours, 1.5 hr ON, 0.5 hr OFF cycle
Endurance at 70°C	±1%: RN41 2D,2E ±3%: RN41 2A ±5%: RN41 2H ±5%: RM41	±0.5%: RN41 2D,2E ±1.5%: RN41 2A ±3%: RN41 2H ±3%: RM41	70°C ± 2°C, 1000 hours, 1.5 hr ON, 0.5 hr OFF cycle
High Temperature Exposure	±1%: RN41	±0.75%: RN41	+125°C, 100 hours

7. Packing

Packing box shall be marked with the following items.

- (1) Type, style and characteristic
- (2) Nominal resistance (3) Quantity
- (4) Lot number (5) Manufacturer's name

Type	Quantity	
	Bulk	Taping
2A	3,000 pcs./box	3,000 pcs./reel
2ES	3,000 pcs./box	3,000 pcs./reel
2D	2,000 pcs./box	2,000 pcs./reel
2E, 2H, 3AS	1,500 pcs./box	1,500 pcs./reel

9. Taping Dimensions/Reel Dimensions

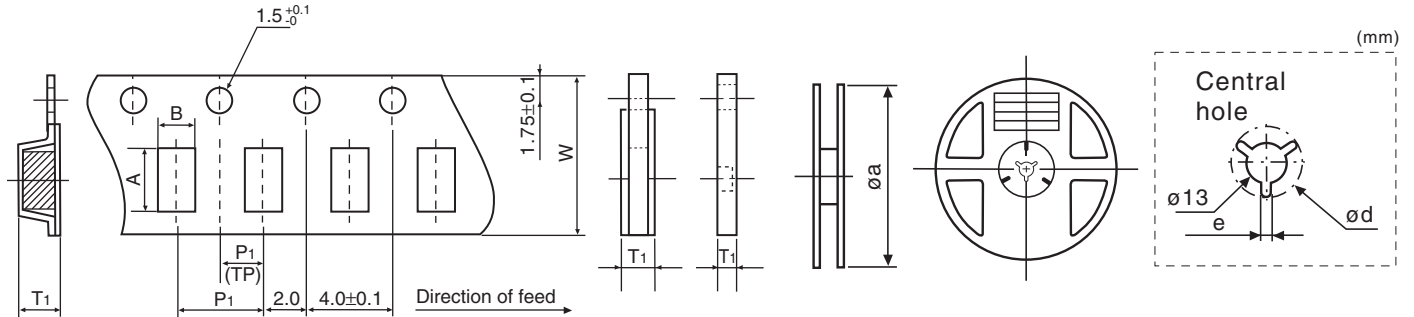

Dimensions in inches (mm)

Type	A	B	W	P1	T1	øa	ød	e
2A	.094 (2.4 ± 0.2)	.059 (1.5 ± 0.2)	.315 (8.0 ± 0.2)	.157 (4.0 ± 0.1)	.059 (1.45 ± 0.2)	7.01 (178)	.827 (21)	.079 (2)
2ES	.146 (3.7 ± 0.2)	.067 (1.7 ± 0.2)	.315 (8.0 ± 0.2)	.157 (4.0 ± 0.1)	.067 (1.7 ± 0.2)	7.01 (178)	.827 (21)	.079 (2)
2D	.146 (3.7 ± 0.2)	.067 (1.7 ± 0.2)	.315 (8.0 ± 0.2)	.157 (4.0 ± 0.1)	.067 (1.7 ± 0.2)	7.01 (178)	.827 (21)	.079 (2)
2E, 2H	.244 (6.2 ± 0.2)	.094 (2.4 ± 0.2)	.472 (12.0 ± 0.1)	.157 (4.0 ± 0.1)	.102 (2.6 ± 0.2)	7.01 (178)	.827 (21)	.079 (2)
3AS	.244 (6.2 ± 0.2)	.094 (2.4 ± 0.2)	.472 (12.0 ± 0.1)	.157 (4.0 ± 0.1)	.102 (2.6 ± 0.2)	10.01 (255)	.827 (21)	.079 (2)

10. Taping Configuration

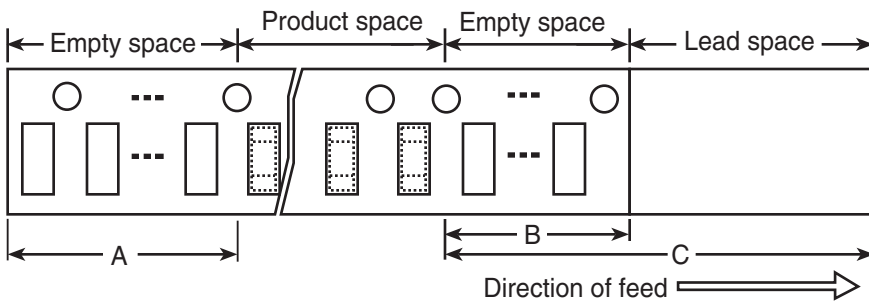

Dimensions in inches (mm)

A min	B min	C min
3.93 (10 pitch)	1.38 (35 pitch)	11.40 (290 mm)