

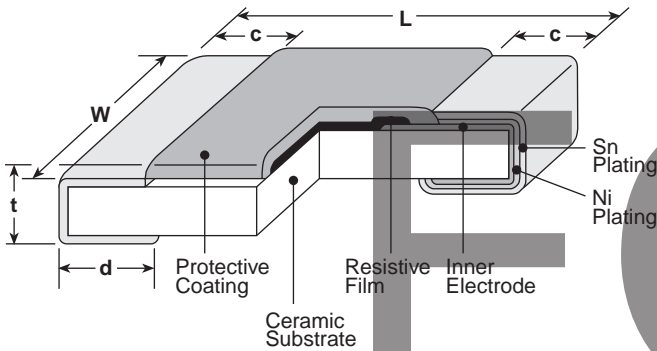

features

- Twelve standard resistance values
- Products with lead-free terminations meet EU RoHS requirements. EU RoHS regulation is not intended for Pb-glass contained in electrode, resistor element and glass.

dimensions and construction



Type (Inch Size Code)	Dimensions inches (mm)				
	L	W	c	d	t
1J (0603)	.063±.008 (1.6±0.2)	.031±.004 (0.8±0.1)	.012±.004 (0.3±0.1)	.012±.004 (0.3±0.1)	.02±.004 (0.5±0.1)
2A (0805)	.079±.008 (2.0±0.2)	.049±.004 (1.25±0.1)	.016±.008 (0.4±0.2)	.012 ^{+0.008} _{-.004} (0.3 ^{+0.2} _{-.1})	.02 ^{+0.008} _{-.004} (0.5 ^{+0.2} _{-.1})
2B (1206)	.126±.008 (3.2±0.2)	.063±.008 (1.6±0.2)	.02±.008 (0.5±0.3)	.016 ^{+0.008} _{-.004} (0.4 ^{+0.2} _{-.1})	.024±.004 (0.6±0.1)

ordering information

NT73	2A	T	TD	103	K	3800	J
Type	Size Code	Termination Material	Packaging	Nominal Resistance	Resistance Tolerance	B Constant Nominal	B Constant Tolerance
	1J: 0603 2A: 0805 2B: 1206	T: Sn (Other termination styles may be available, please contact factory for options)	TD: 7" paper tape (5,000 pieces/reel)	2 significant figures + 1 multiplier	J: ±5% K: ±10% L: ±15%	3200 3500 3700 3800 3950 4100	H: ±3% J: ±5% K: ±10%

applications and ratings

Part Designation	Resistance @ 25°C	Resistance Tolerance	B Constant @ 25°C/75°C	B Constant Tolerance	Power Rating (mW)	Operating Temperature Range
NT731J	6.8kΩ	J: ±5% K: ±10%	3500K	±10%	5	-55°C to +125°C
	10kΩ			±5%		
	15kΩ					
	10kΩ		3700K	±3%		
	20kΩ			±5%		
	22kΩ					
	30kΩ		3800K	±5%		
	33kΩ					
	47kΩ					
	68kΩ		4100K	±3%		
	100kΩ					
	47kΩ					
NT732A	1kΩ	K: ±10% L: ±15%	3200K	±10%	5	
	2kΩ					
	2.2kΩ					
	2.4kΩ					
	3.3kΩ	J: ±5%; K: ±10% L: ±15%	3500K	±5%		
	4.7kΩ					
	5kΩ					
	5kΩ					

For further information on packaging, please refer to Appendix A.

Specifications given herein may be changed at any time without prior notice. Please confirm technical specifications before you order and/or use.

5/31/24

applications and ratings (continued)

Part Designation	Resistance @ 25°C	Resistance Tolerance	B Constant @ 25°C/75°C	B Constant Tolerance	Power Rating (mW)	Operating Temperature Range			
NT732A	6.8kΩ	K: ±10%; L: ±15%	3800K	±10%	5	-55°C to +125°C			
	10kΩ		3500K						
	15kΩ		J: ±5% K: ±10% L: ±15%	3800K			±5%		
	10kΩ								
	20kΩ								
	22kΩ								
	30kΩ			4100K			±3%		
	33kΩ								
	47kΩ			3200K			±10%		
	68kΩ								
	100kΩ								
	150kΩ								
	50kΩ							J: ±5% K: ±10% L: ±15%	±5%
	10kΩ								
	15kΩ								
	20kΩ								
22kΩ									
30kΩ									
33kΩ									
47kΩ									
68kΩ									
100kΩ									
150kΩ									

Thermal dissipation constant - in the atmosphere - (reference) 1J: 2.0mW/°C, 2A: 2.8mW/°C, 2B: 3.0mW/°C

thermal sensors

environmental applications

Temperature Characteristics

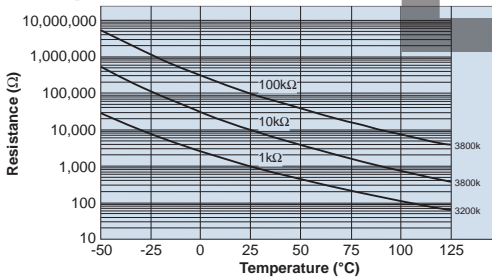

RT/R25 Ratio vs. B Constant

Resistance	B Constant					Resistance	B Constant				
	3200K	3500K	3700K	3800K	4100K		3200K	3500K	3700K	3800K	4100K
Temp. (°C)	Ω	k Ω	k Ω	k Ω	k Ω	Temp. (°C)	Ω	k Ω	k Ω	k Ω	k Ω
-55	38770	273.24	638.23	7692.5	1203.1	40	604.07	2.8809	5.5500	54.959	5.1999
-50	28840	197.67	465.81	5414.6	820.76	45	515.10	2.4202	4.6100	45.484	4.2349
-45	21706	144.85	343.25	3864.5	568.09	50	441.00	2.0421	3.8500	37.823	3.4692
-40	16517	107.43	255.22	2794.3	398.57	55	379.00	1.7302	3.2300	31.594	2.8585
-35	12698	80.577	191.37	2045.2	283.20	60	326.90	1.4718	2.7200	26.506	2.3682
-30	9857.0	61.077	144.64	1514.1	203.64	65	282.95	1.2598	2.3100	22.330	1.9721
-25	7721.2	46.759	110.13	1133.0	148.07	70	245.72	1.0771	1.9700	18.886	1.6904
-20	6100.5	36.137	83.710	856.49	108.37	75	214.08	0.92637	1.6800	16.035	1.3877
-15	4858.7	28.173	64.190	653.63	80.182	80	187.08	0.79937	1.4500	13.663	1.1724
-10	3899.0	22.147	49.640	503.31	59.943	85	163.96	0.69199	1.2500	11.682	0.99491
-5	3151.3	17.546	38.680	390.86	45.252	90	144.11	0.60087	1.0800	10.022	0.84926
0	2564.2	14.004	30.370	305.97	34.478	95	127.00	0.52329	0.94000	8.6257	0.72802
5	2099.9	11.256	23.970	241.34	26.473	100	112.21	0.45701	0.82000	7.4466	0.62662
10	1730.0	9.1063	19.070	191.73	20.506	105	99.377	0.40016	0.72000	6.4466	0.54156
15	1433.5	7.4135	15.270	153.36	16.016	110	88.224	0.35129	0.63000	5.5968	0.46982
20	1194.2	6.0712	12.320	123.46	12.608	115	78.501	0.30915	0.56000	4.8721	0.40906
25	1000.0	5.0000	10.000	100.00	10.000	120	70.004	0.27272	0.49000	4.2523	0.35741
30	841.48	4.1398	8.1700	81.470	7.9880	125	62.558	0.24114	0.44000	3.7207	0.31332
35	711.39	3.4451	6.7100	66.739	6.4242						

Performance Characteristics

Parameter	Requirement Limit	R ±(%+0.05Ω)		Test Method
		Typical		
Resistance	Within specified tolerance	—	25°C	
B Constant	Within specified tolerance	—	+25°C/+75°C	
Resistance to Solder Heat	Other: ±1%, ±2%:1kΩ	Other: ±0.5%, ±1%:1kΩ	260°C ± 5°C, 10 seconds ± 1 second	
Rapid Change of Temperature	±3.0%	±1.3%	-55°C (30 minutes), +125°C (30 minutes), 50 cycles	
Moisture Resistance	±3.0%	±1.1%	40°C ± 2°C, 90 - 95% RH, 1000 hours	
Load Life	±3.0%	±2.5%	80°C ± 2°C, DC5mW, 1000 hours	
High Temperature Exposure	±3.0%	±1.6%	80°C, 1000 hours	

Confirming resistance drift is recommended since this product has a tendency to have bigger resistance change than general flat chip over 80°C. Please pay attention not to be applied ESD, it may cause of resistance change.

Actual Value (Out of Guarantee)

Test Items	Reference	Test Method
High Temperature Exposure	±7.0%	125°C, 1000 hours
ESD	500V	Human model, 100 pF 1.5 kΩ