

features

- Twenty-five specifiable temperature characteristics
- Products with lead-free terminations meet EU RoHS requirements. EU RoHS regulation is not intended for Pb-glass contained in electrode, resistor element and glass.

EOL

dimensions and construction

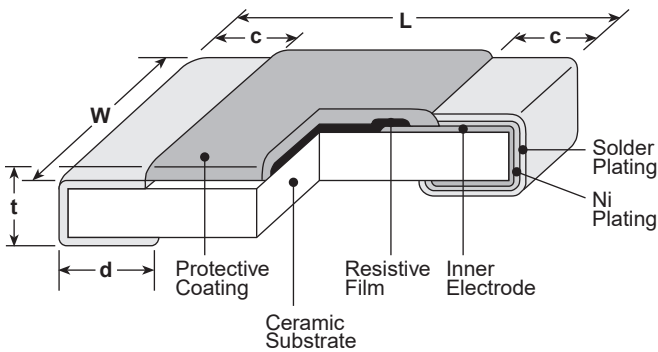

Type (Inch Size Code)	Dimensions inches (mm)				
	L	W	c	d	t
1J (0603)	.063±.008 (1.6±0.2)	.031±.004 (0.8±0.1)	.012±.004 (0.3±0.1)	.012±.004 (0.3±0.1)	.018±.004 (0.45±0.1)
2A (0805)	.079±.008 (2.0±0.2)	.049±.004 (1.25±0.1)	.016±.008 (0.4±0.2)	.012 ^{+0.008} _{-0.004} (0.3 ^{+0.2} _{-0.1})	.02±.004 (0.5±0.1)
2B (1206)	.126±.008 (3.2±0.2)	.063±.008 (1.6±0.2)	.02±.008 (0.5±0.3)	.016 ^{+0.008} _{-0.004} (0.4 ^{+0.2} _{-0.1})	.024±.004 (0.6±0.1)

ordering information

LA73	1J	T	TD	101	J	3300
Type	Size Code	Termination Material	Packaging	Resistance Value	Tolerance	T.C.R.
	1J: 0603 2A: 0805 2B: 1206	T: Sn (Other termination styles available, contact factory for options)	TD: 7" paper (5,000 pieces/reel)	2 significant figures + 1 multiplier	J: ±5%	

For further information on packaging, please refer to Appendix A.

applications and ratings

Part Designation	Thermal Dissipation Constant (mW/°C)	Rated Ambient Temp.	Max. Working Voltage (V)
LA731J	7.6	+70°C	25
LA732A	8.2		50
LA732B	9.0		50

Operating Temp. Range: -55°C - +125°C

Resistance Range E-12			T.C.R. Tolerance	T.C.R. (ppm/°C) Max.	Resistance Tolerance
LA731J	LA732A	LA732B			
1KΩ - 10KΩ	1KΩ - 10KΩ	1KΩ - 10KΩ	±200ppm/°C	1000	J: ±5%
680Ω - 6.8KΩ	680Ω - 6.8KΩ	680Ω - 6.8KΩ		1200	
470Ω - 4.7KΩ	470Ω - 4.7KΩ	470Ω - 4.7KΩ		1400	
470Ω - 3.9KΩ	470Ω - 3.9KΩ	470Ω - 3.9KΩ		1600	
330Ω - 2.7KΩ	330Ω - 2.7KΩ	330Ω - 2.7KΩ		1800	
330Ω - 2.7KΩ	330Ω - 2.7KΩ	330Ω - 2.7KΩ		2000	
220Ω - 1.8KΩ	220Ω - 1.8KΩ	220Ω - 1.8KΩ	±10%	2200	
220Ω - 1.2KΩ	220Ω - 1.2KΩ	220Ω - 1.2KΩ		2400	
100Ω - 1.2KΩ	100Ω - 1.2KΩ	100Ω - 1.2KΩ		2600	
100Ω - 390Ω	100Ω - 390Ω	100Ω - 390Ω		2800	
68Ω - 220Ω	68Ω - 220Ω	68Ω - 220Ω		3000	
33Ω - 120Ω	33Ω - 120Ω	33Ω - 120Ω		3300	
22Ω - 82Ω	22Ω - 82Ω	22Ω - 82Ω		3600	

environmental applications

Derating Curve

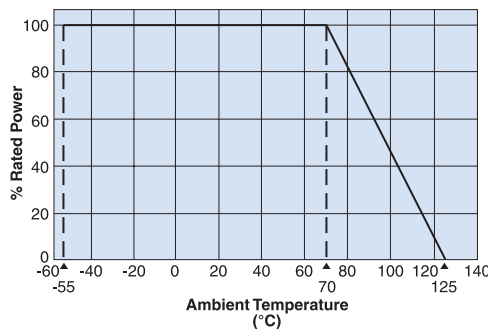

Temperature Characteristics

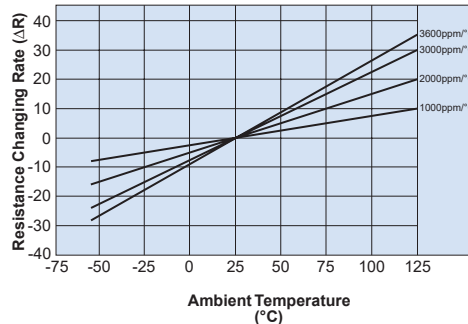

Approximate Expression for Resistance-Temperature Characteristics

T.C.R. (x10 ⁻⁶ /K)	C ₀	C ₁	C ₂
3000	0.926	0.00294	1.1 x 10 ⁻⁷
3300	0.918	0.00325	4.1 x 10 ⁻⁷
3600	0.910	0.00359	1.7 x 10 ⁻⁷

(Values are not guaranteed but typical)

$$R_T = R_{25} (C_0 + C_1 T + C_2 T^2)$$

R_T: Resistance value at T°C

R₂₅: Resistance value at 25°C

T: Ambient temperature (°C)

C₀, C₁, C₂: Constants

Performance Characteristics

Parameter	Requirement ΔR ±(% + 0.1%)		Test Method
	Limit	Typical	
Resistance	Within specified tolerance	—	25°C
T.C.R.	Within specified T.C.R.	—	+25°C/+75°C
Overload (Short time)	±1.0%	±0.5%	Rated voltage x 2.5 or maximum working volume x 2 for 5 seconds, whichever is lower
Resistance to Solder Heat	±1.0%	±0.5%	260°C ± 5°C, 10 seconds ± 1 second
Rapid Change of Temperature	±1.0%	±0.5%	-55°C (30 minutes)/ +125°C (30 minutes), 100 cycles
Moisture Resistance	±3.0%	±1.5%	40°C ± 2°C, 90 - 95% RH, 1000 hours, 1.5 hr ON, 0.5 hr OFF cycle
Endurance at 70°C	±3.0%	±1.5%	70°C ± 2°C, 1000 hours, 1.5 hr ON, 0.5 hr OFF cycle

Confirming resistance drift is recommended since this product has a tendency to have bigger resistance change than general flat chip over 70°C.

Please pay attention not to be applied ESD, it may cause of resistance change.

Actual Value (Out of Guarantee)

Test Items	Reference	Test Method
High Temperature Exposure	±3.0%	125°C, 1000 hours
ESD	300V	Human model, 100 pF 1.5 kΩ

Specifications given herein may be changed at any time without prior notice. Please confirm technical specifications before you order and/or use.

12/16/11