

### features

- Suitable for automatic machine insertion
- No rating
- Products with lead-free terminations meet EU RoHS and China RoHS requirements

### dimensions and construction

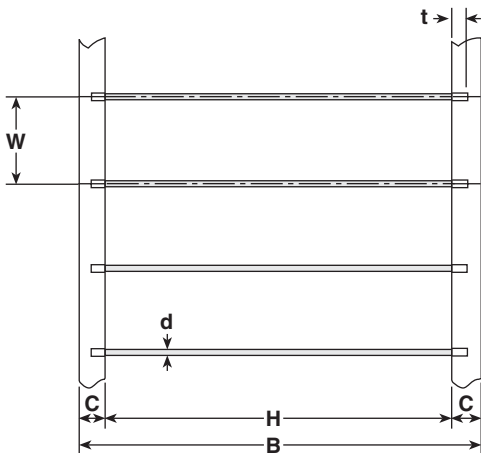

T52 Type	Dimensions inches (mm)					
	H	B	C	W	t (max.)	d nominal
JL5						.02 (0.5)
JL6	2.05±.039 (52.0±1.0)	2.56±.039 (65.0±1.0)	.244±.02 (6.2±0.5)	.2±.015 (5.08±0.38)	.098 (2.5)	.024 (0.6)
JL8						.031 (0.8)

T26 Type	Dimensions inches (mm)					
	H	B	C	W	t (max.)	d nominal
JL5						.02 (0.5)
JL6	1.02 <sup>+0.039</sup> <sub>-0</sub> (26.0 <sup>+1</sup> <sub>-0</sub> )	1.54±.039 (39.0±1.0)	.244±.02 (6.2±0.5)	.1972±.02 (5.0±0.5)	.098 (2.5)	.024 (0.6)
JL8						.031 (0.8)

### applications and ratings

Part Designation	Maximum Resistance	Maximum Current Ratings
JL5	10mΩ	8 Amps
JL6		10 Amps
JL8		12 Amps

### ordering information

JL	8	C	T52	A
Type	Nominal Diameter	Termination Material	Taping and Forming	Packaging
	5 (24 gauge) 6 (22 gauge) 8 (20 gauge)	C: SnCu (Other termination styles available, contact factory for options)	T26, T52	A: Ammo

For further information on packaging, please refer to Appendix C.